

micro DOUBLE SIX SWITCH

*micro*HAM

fax: +421 2 4594 5100
e-mail: support@microham.com
homepage: www.microham.com



5 December 2011

TABLE OF CONTENTS

CHAPTER		PAGE
1.	IMPORTANT WARNINGS	3
2.	DESCRIPTION	3
3.	CHARACTERISTICS AND FUNCTIONS	3
4.	INSTALLATION	5
5.	CONFIGURATION	8
6.	TYPICAL PERFORMANCE	10
7.	PACKAGE CONTENTS	13
8.	WARRANTY	13
9.	SPECIFICATIONS	14

IMPORTANT WARNINGS

Never operate the antenna switch with the case open

When installing at elevated site, always observe proper safety precautions

Protect the inside of switch from humidity

DESCRIPTION

micro DOUBLE SIX SWITCH ("antenna switch") is a remotely operated antenna switch (antenna relay). It can select six antennas to one of two common ports (output) and can be installed either in the shack or on the tower.

CHARACTERISTICS AND FUNCTIONS

- 6 antenna positions enable use of separate antennas for up to six bands.
- massive cast aluminum (wall thickness 4mm/0.158") IP 66 class enclosure with "O"-ring seal guarantees a high level of protection against weather and RF interference
- enclosed relays have insulation voltage of 10KV, contacts are of high silver content alloy
- microstrip PCB architecture with a compensated stub provides low SWR and insertion loss in the range of 1.7 to 30 MHz
- integrated surge protection
- compatible with any band decoder with 12V source output
- lid screws are secured against fallout
- easily installable to wall or to tower using a massive fixture in the shape of double C, enabling installation on tubes (tower legs) of various diameters
- all antenna ports are grounded without power
- all unselected antenna ports are grounded
- two level interlock against connecting the same antenna to both outputs

INSTALLATION

The antenna switch is intended to be used either inside or outside.

Installing inside the shack

If the switch is operated inside the shack, it can be installed in any position.

It can be installed onto the wall using 4 screws (see Fig.1)

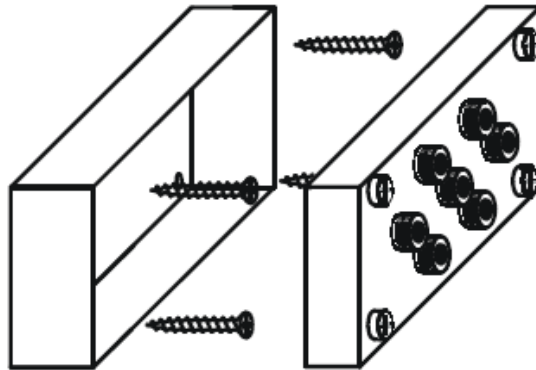

Fig. 1

or using the L-fixture, connectors up, or down (see Fig.2).

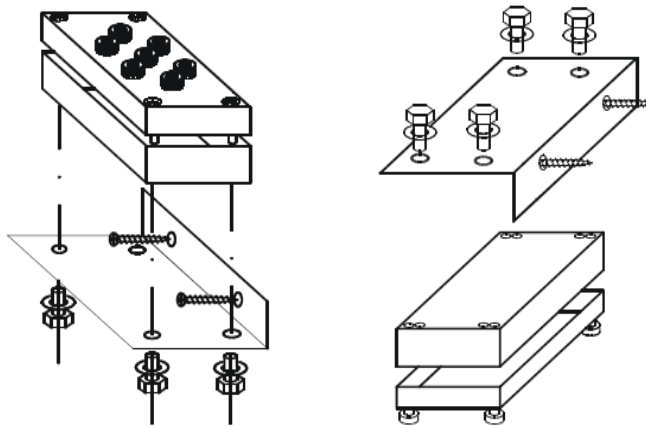

Fig. 2

Installing outside the shack :

When installed outside the shack on a tower, the orientation of switch is of great importance. Mounting the switch in any way other than connectors down may result in moisture leakage into the enclosure. Moisture accumulation may cause improper operation, adversely influence function, and even may result in a failure of the switch.

Always install the switch in position with connectors down! Use the L-plate and the double-C-clamps. First install the mounting hardware to the tower: position the part (1) next to part (2) . Push the long screws (3) through these parts and fix the screws inside part (2) using washers and nuts. Place these parts on the tower, from back side push part (2) onto the screws with teeth to the mast and fix using washers and nuts.

Then using 4 short screws and lock washers (4) install the box of the antenna switch. Finally attach the antenna switch lid using the four captive screws from the bottom side.

The installation procedure is illustrated on Fig. 3.

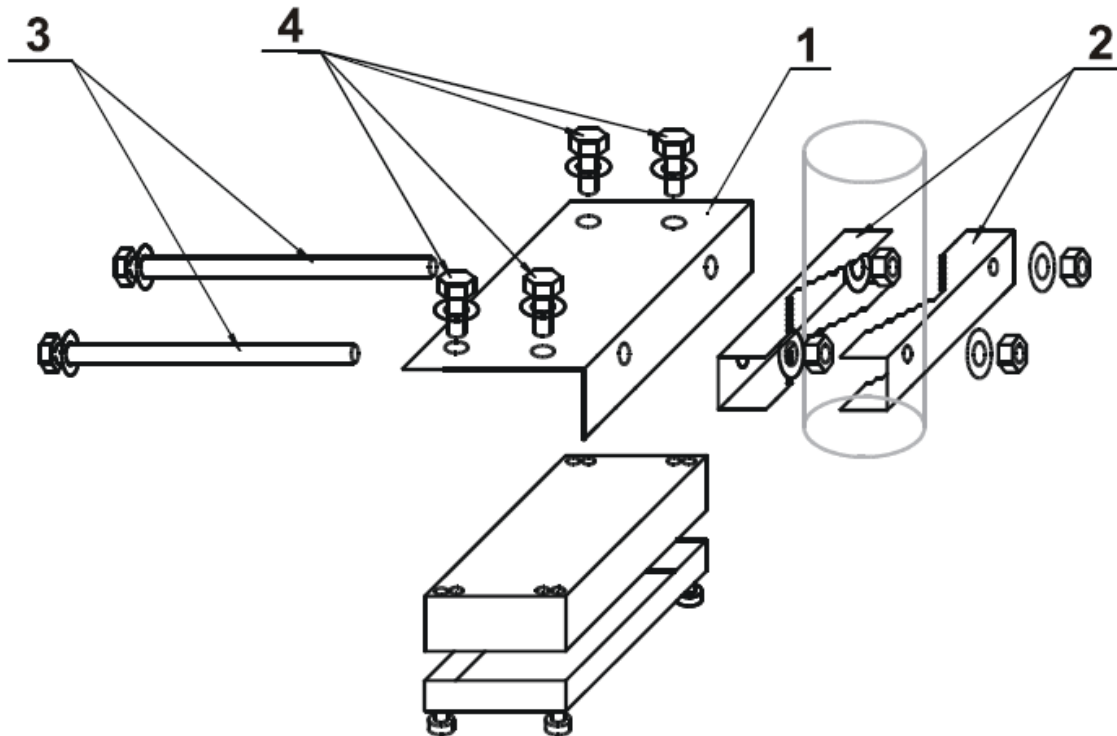

Fig.3

Before fixing the switch lid, carefully dry the whole box and the lid, optionally insert humidity absorber into the box. After installation and functional testing fix and tighten all connectors and insulate them using a suitable tape. Also insulate all unused ports or use protection caps.

Connecting the Switch:

micro DOUBLE SIX SWITCH connects directly to microHAM Station Master or other band decoders and antenna selectors providing +12 to +16 volts to select an antenna. Connect the top terminals B1 – B6 (shown at the right in figure 4 below) to the antenna select outputs and the GND terminal to the ground or DC return terminal of the band decoder or antenna controller for one radio. Connect the bottom terminals A1 - A6 to the antenna select outputs and the GND terminal to the ground or DC return terminal of the band decoder or antenna controller for the other radio.



Fig. 4

Configure your controller or band decoder to activate the appropriate output for the desired antenna on each band. With some decoders it may be necessary to use “summing diodes” or connect multiple outputs to a single control lead – for example when using a multiband antenna.

If the micro DOUBLE SIX SWITCH is going to be placed outside, your band decoder should have relay outputs or you should use an auxiliary relay driver board to protect any decoder with solid state drivers. Remember, that the best protection is a galvanic isolation with a high isolation voltage.

Cable length vs. Wire Size:

If antenna switch is located some distance from the decoder or controller, it is necessary to use a cable of the appropriate length and wire size.

Cable length [m] / [ft]	Conductor diameter [mm]	Conductor Cross-section [mm²]	AWG
50 /150	0.4	0.14	26
100 /300	0.5	0.2	24
300 /1000	0.8	0.5	20

It is helpful (although not necessary) to use a shielded cable with the shield used as an added ground lead to reduce voltage losses. Connect one end of the cable to the terminals of antenna switch and solder the other end to an appropriate connector for your controller or band decoder. *micro* DOUBLE Six Switch requires two cables with seven conductors (six antennas plus return/ground); it is convenient to use shielded CAT5/CAT6 cable and parallel the extra wire plus shield with the seventh (return) conductor. Shielded CAT5/CAT6 with the extra return conductors will be more than sufficient for 300 m /1000 ft.

CONFIGURATION

The antenna switch enables switching 6 antenna ports to either of two radio ports. The basic configuration is such that each primary (contest) band from 160m to 10m has a separate antenna port - port 1 for 160m, port 2 for 80m, etc.

The *micro*HAM Band Decoder (discontinued) and *micro*HAM Station Master (Port A) have DB25 connectors for connecting an antenna switch. Typical connection are shown in the following table :

Band	DB25M	Antenna port
160	20	1
80	21	2
40	22	3
20	23	4
15	24	5
10	25	6
GND	18, 19	

Table 2

If you have multiple antennas on one band, it will be necessary to select them using an external switch. For example:

Band	Antennas
160	Dipole
80	Delta Loop, Inverted - V
40	XM-402
20, 15, 10	Tribander
30, 17, 12	WARC Tribander

Typical connecting cable with auxiliary switch:

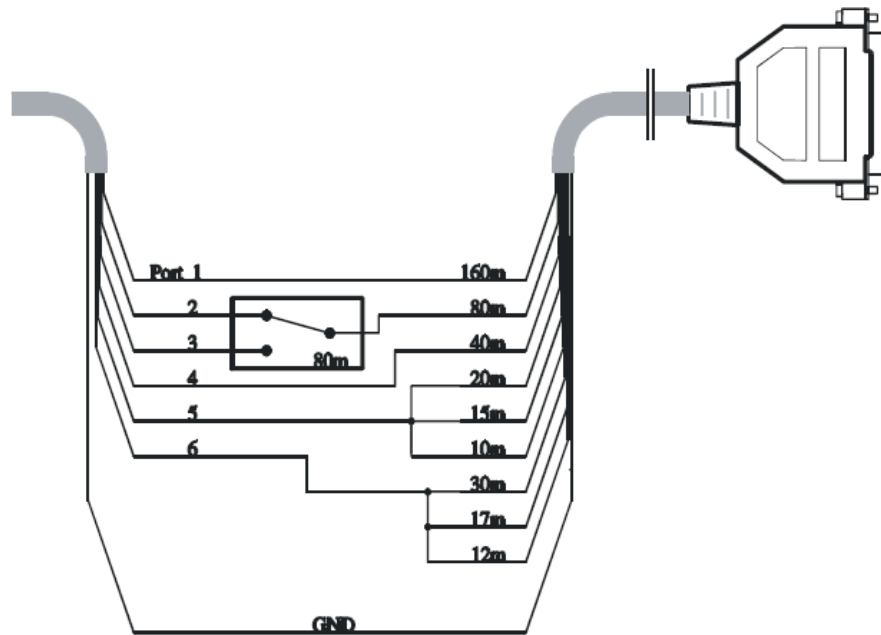

Fig. 6

Assign Decoder outputs and connect antennas to the switch ports as shown:

Decoder Output	Antenna	Switch Port
160	Dipole	1
80	Delta Loop	2
80	Inv-V	3
40	XM-402	4
20, 15, 10	Tribander	5
30, 17, 12	WARC Tribander	6

An external two-position switch (or Band Decoder option) will be needed for 80 meters in each cable. Station Master includes the option to select from among multiple antennas per band.

Manual Control:

microDOUBLE SIX Switch is also usable without an automatic Band Decoder. In such case the user will need to supply a manual 1 of 6 switch for each half of the switch. The design for such a switch is shown at Figure 7.

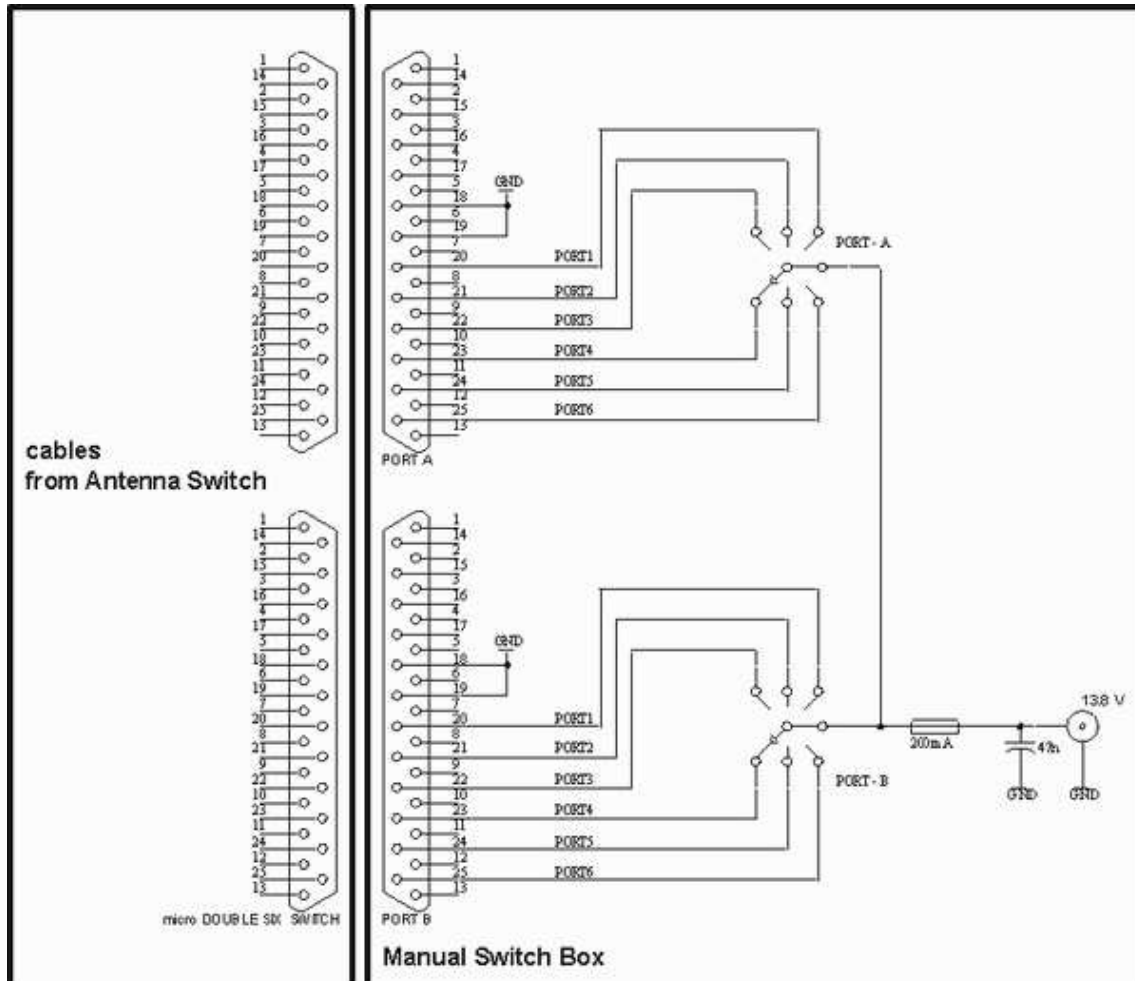

Fig. 7

TYPICAL PERFORMANCE

The following figures show measurements on port 1. More detailed results for all ports are available at www.microham.com

SWR :

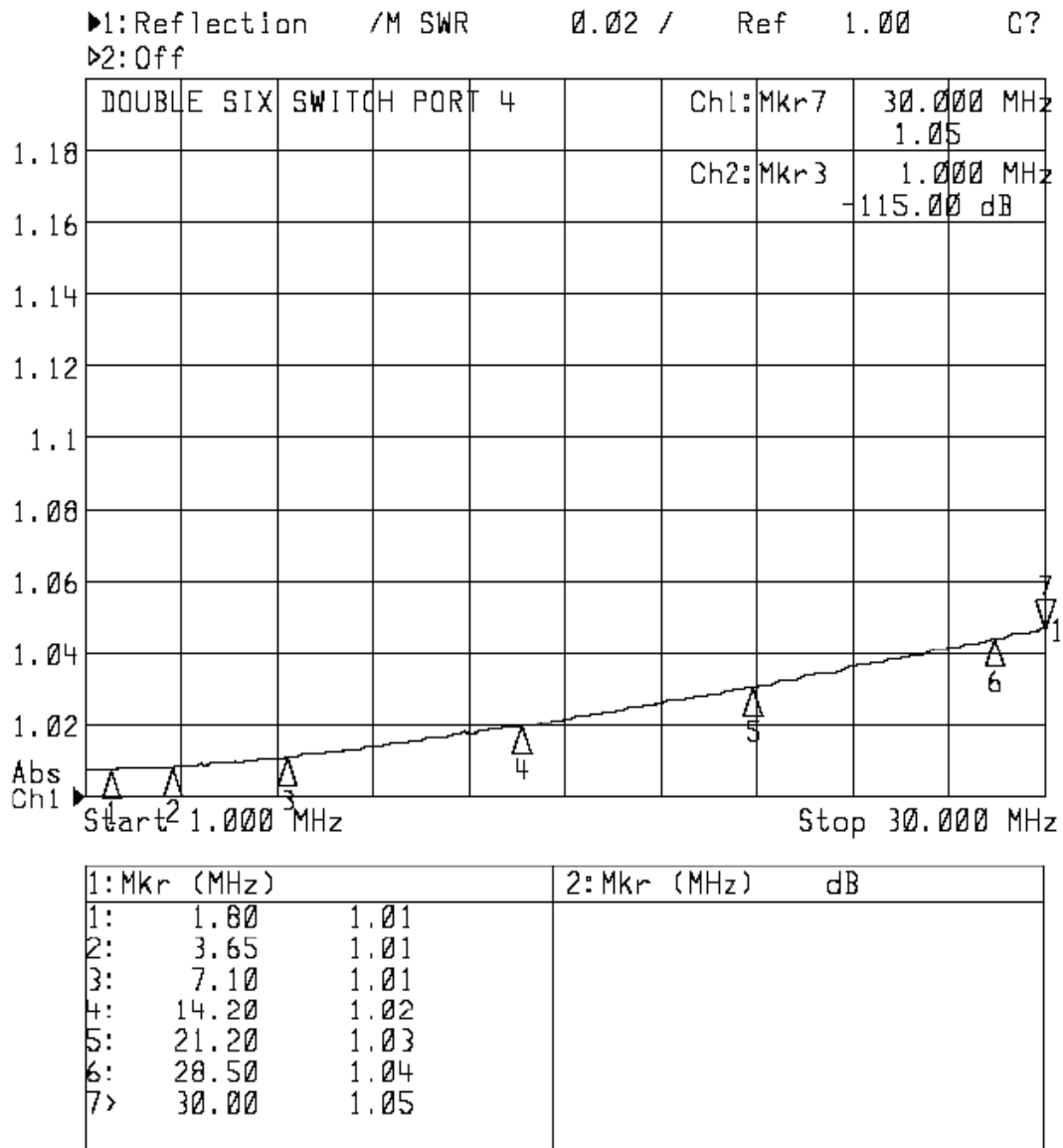

Fig. 7

SWR is measured from the input to the selected antenna port.

Insertion loss :

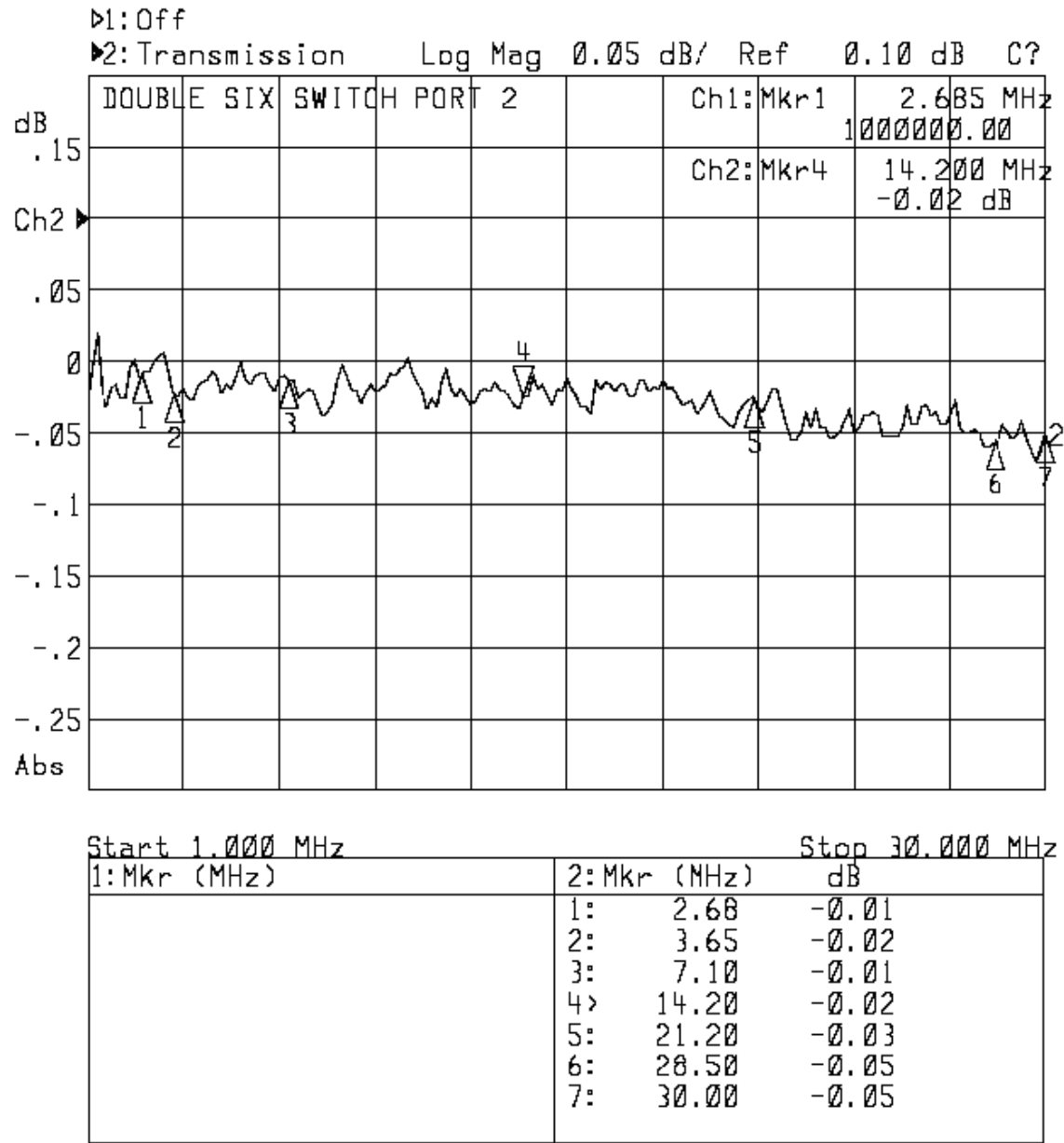

Fig. 8

Isolation: (A to PORT 3, B to Port 5)

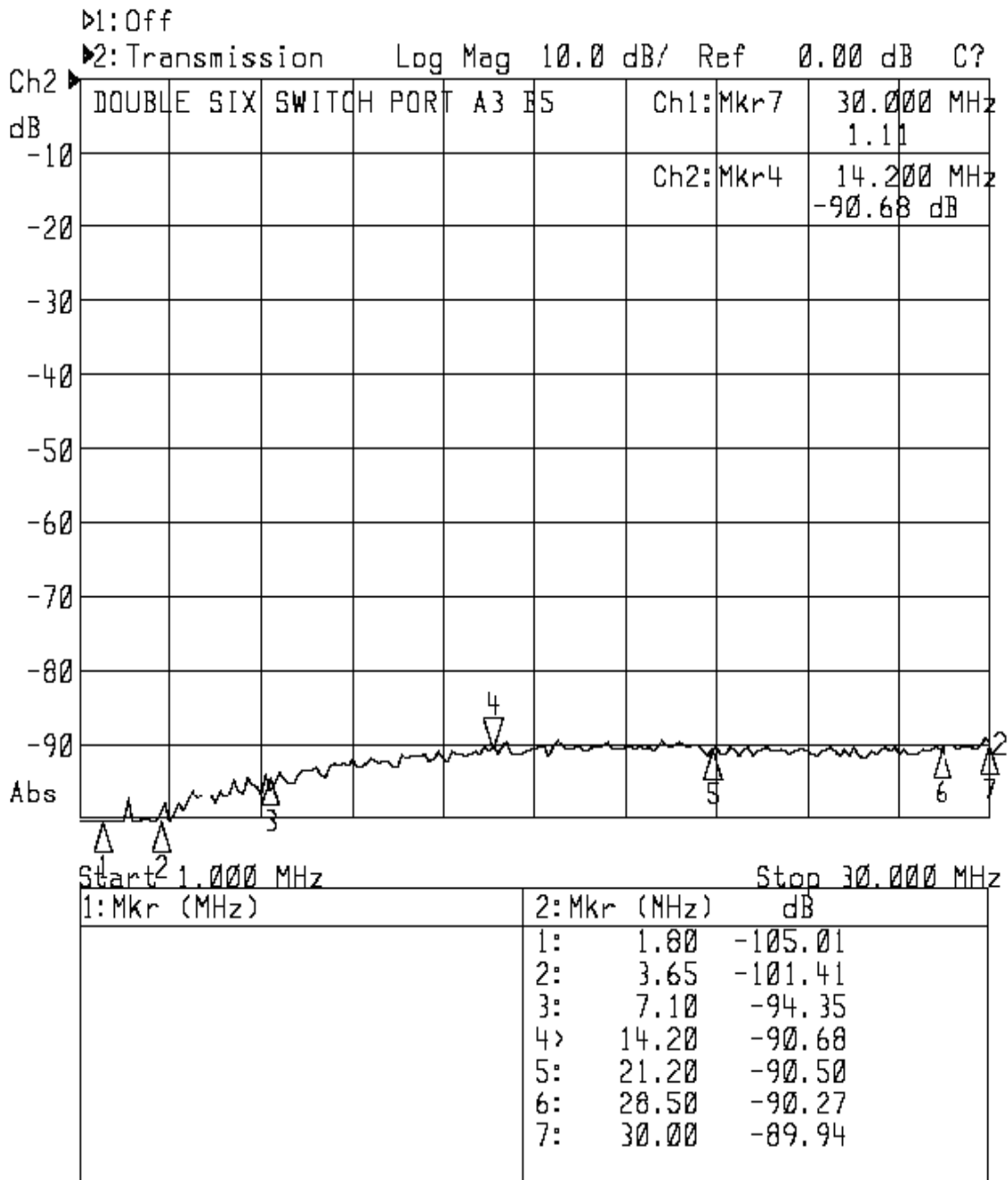

Fig. 9

Isolation is measured as the signal level at any unused port relative to the signal level from the input with the selected port terminated in 50 ohms.

PACKAGE CONTENTS

The product includes micro DOUBLE SIX SWITCH and mounting bracket.

If the shipment is incomplete, please contact us at the following address:

E-mail: support@microham.com

fax : +421 2 4594 5100

by Post: **microHAM s.r.o.**
Nadrazna 36
90028 Ivanka pri Dunaji
SLOVAKIA

WARRANTY

microHAM warrants this product for three (3) years. The product must not be modified in any way or the warranty is voided.

What is covered: During the warranty, *microHAM*, s.r.o., will repair or replace defective product at their sole discretion. You must send the unit postpaid with a copy of the original invoice to the distributor from whom you purchased the product. *microHAM* will pay return shipping.

What is not covered: This Limited Warranty does not cover (1) damage caused by misuse, negligence, user modifications or failure to follow the user manual, (2) connection to improper or excessive voltage or voltage surges, (3) the incorrect installation of any cables connected to the device by the user, (4) weather related storm, lightning or electrostatic discharge damage, or (5) damage due to switching with RF power applied (“hot” switching). .

microHAM assumes no liability or responsibility for damage to other devices or injuries to persons as a consequence of using our products.

If the terms of the above warranty are not acceptable, return the unit, all associated documents and accessories in the original unopened package, prepaid, to microHAM or to your supplier for refund less shipping and a restocking fee.

SPECIFICATIONS

Frequency range :	1,7 - 30 MHz
Characteristic impedance :	50 ohm
Number of antenna ports :	6
Number of radio ports :	2
Supply voltage :	+12 to +16V DC to select
Consumption :	max. 180mA
Isolation voltage of relays :	10KV
Connectors :	PTFE SO239 or N, depending on version
SWR: (typical)	2 MHz < 1.03 : 1
	30 MHz < 1.06 : 1
Insertion loss: (typical)	2 MHz < 0.01 dB
	30 MHz < 0.05 dB
Isolation: (depending on port)	2 MHz: 80 - 115 dB
	30 MHz: 60 - 90 dB
Guaranteed power rating :	
SWR <1.3 :1	30 MHz < 5KW
SWR <2 : 1	30 MHz < 3KW
SWR <3 : 1	30 MHz < 2KW
Operating temperature range :	-35 .. +70 C (-31.. 158 F)
Dimensions:	W 220mm (8,66") x H 103 mm (4") x D 120 mm (4.72")
Weight:	2,4 kg (5.29 lbs) + 1,1 kg (2.42 lbs) fixture